



Kingston Low Carbon District Heating Network

17th November 2022





Where? Royal Borough of Kingston upon Thames

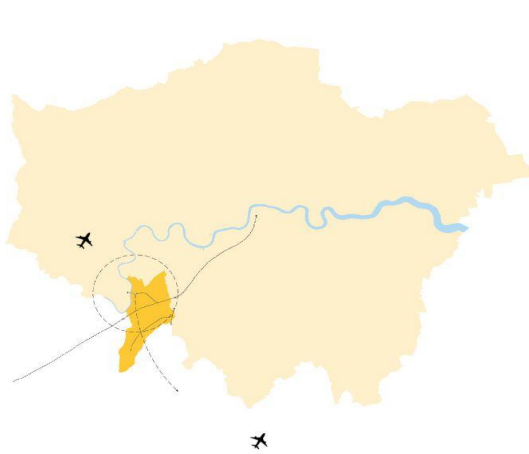
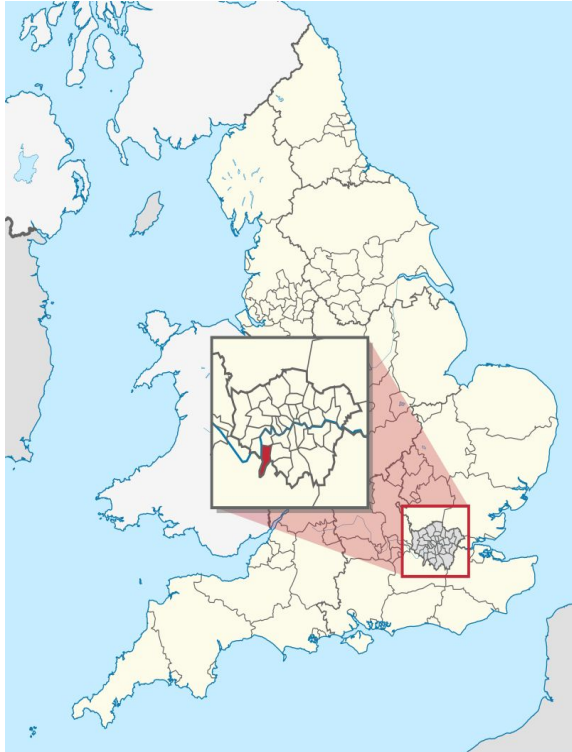

London's 3rd smallest borough but still a population of 178,000 similar in size to Sunderland

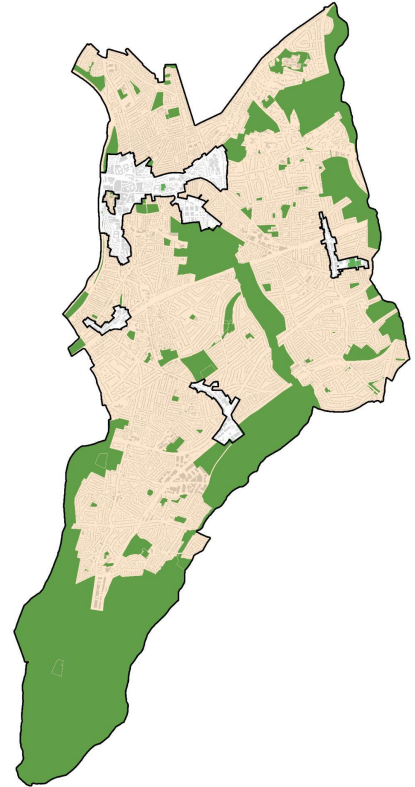

Royal Borough of Kingston upon Thames

A happy place to live (voted in London top 3)

Heathrow Airport
(30 minutes by car)

11 miles from London Waterloo
(17 minutes by train)

Gatwick Airport
(45 minutes by car)

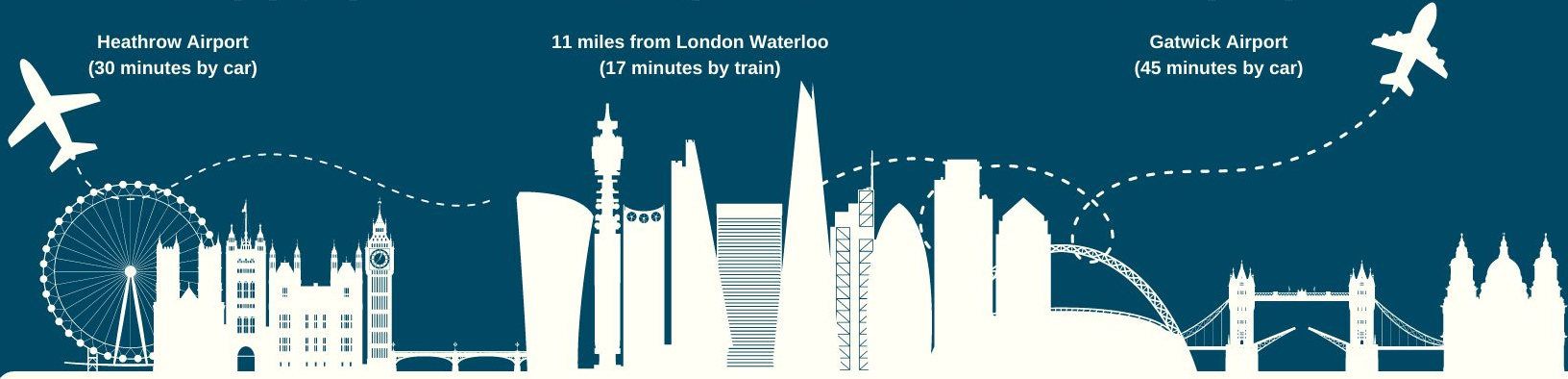

**Oldest
Royal
Borough**



Population

+12%



179,000 (2020) - 200,000

by 2040



Active local
businesses

10,200

KS4 students
attaining GCSE
grade 5 and above
in English & Maths

61.9%

compared to 58.5%
across London



Residents who are educated
to Degree level or equivalent
and above

65.2%

compared to 58.9% across London

73% of borough based schools and colleges
Ofsted rated Outstanding or good

Tiffin School for girls #2 on the 2022, Best
Grammar Schools in the UK Top 50 League
Table

Kingston University has 16,000 students, is
in the 'Top 50' institution nationally, 'Top 2'
ranked 'young institution' in the country.

Employment
(working age 16-64)

80.4%



compared to 74.8% in
London

Major employers include:
Saipem, Chessington World of
Adventures, John Lewis
Partnership, Travel Republic,
Unilever, BAE Systems, New
England Seafoods, Bausch and Lomb.

£1bn+

development investment over the past
7 years



www.kingston.gov.uk/invest



This is the Royal Borough of Kingston upon Thames



Kingston metropolitan town centre

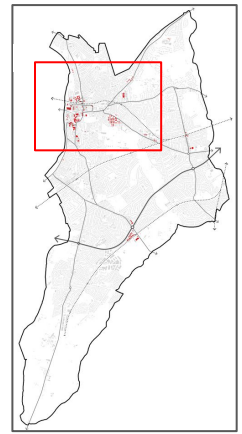
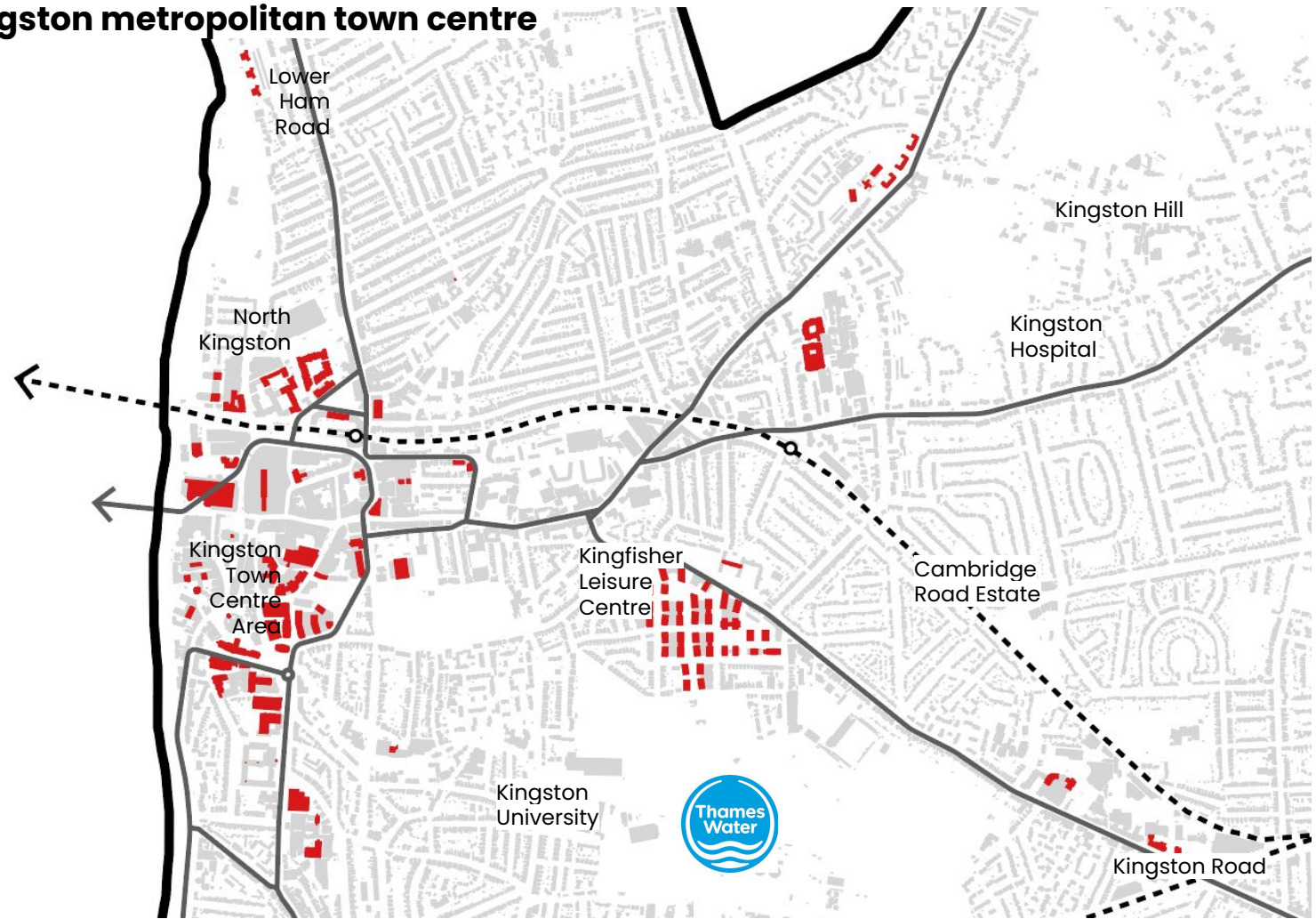



The Opportunity: Low Carbon wastewater heat from Thames Water sewer outfall into Hogsmill River





The Opportunity: Thames Water Hogsmill Wastewater Treatment works, Nortbiton





The Opportunity: Carbon & environmental sustainability benefits

= Huge quantity waste heat (50 GWh PA) available from Thames Water Hogsmill sewage treatment plant

= Saving of 6,900 t/CO₂ per annum over gas boilers (Full Build Out)

= Equivalent to making 8,300 homes net zero carbon for heating

= CHP engines utilizing biogas from treatment process to power heat pumps to raise water temperatures

= 39 GWh heat pa produced/consumed (Full Build Out of 'Kingston Core Network')

BuroHappold Preliminary Feasibility Study (Jan 2022)

= Environmental regeneration of the Hogsmill river and habitats



The Opportunity: off take proximity

As the crow flies:
300m to CRE

500m to RBK
swimming pool

1,000m to University

1,200m to Crown
Court

1,300m to Eden Walk
and County Hall

1,500m to Guildhall
and Kingston Hospital

4 schools on route, 1
on N route

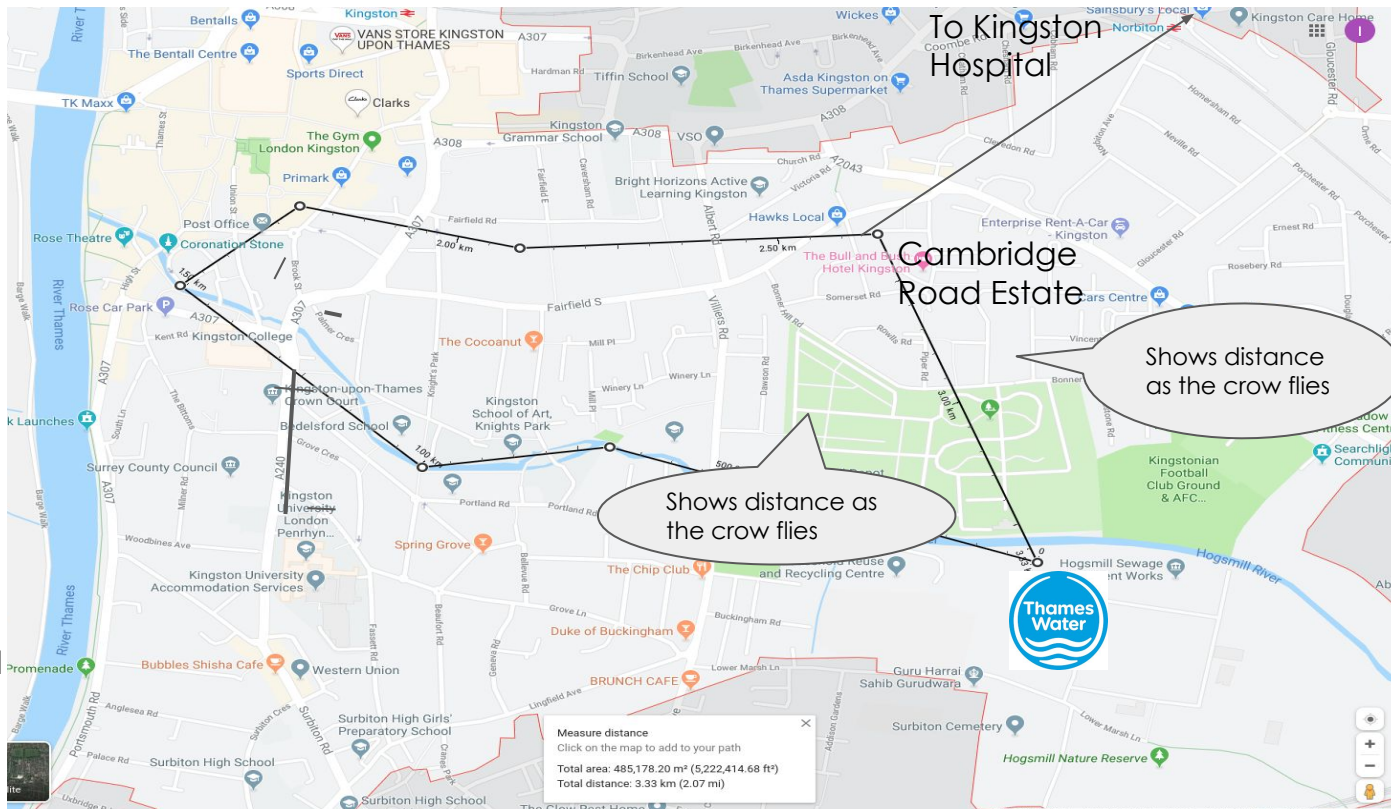



The Opportunity: New Development @ the Cambridge Road Estate

- *Over 800 existing poor quality homes and energy inefficient*
- *Health inequality i.e. Low life expectancy*

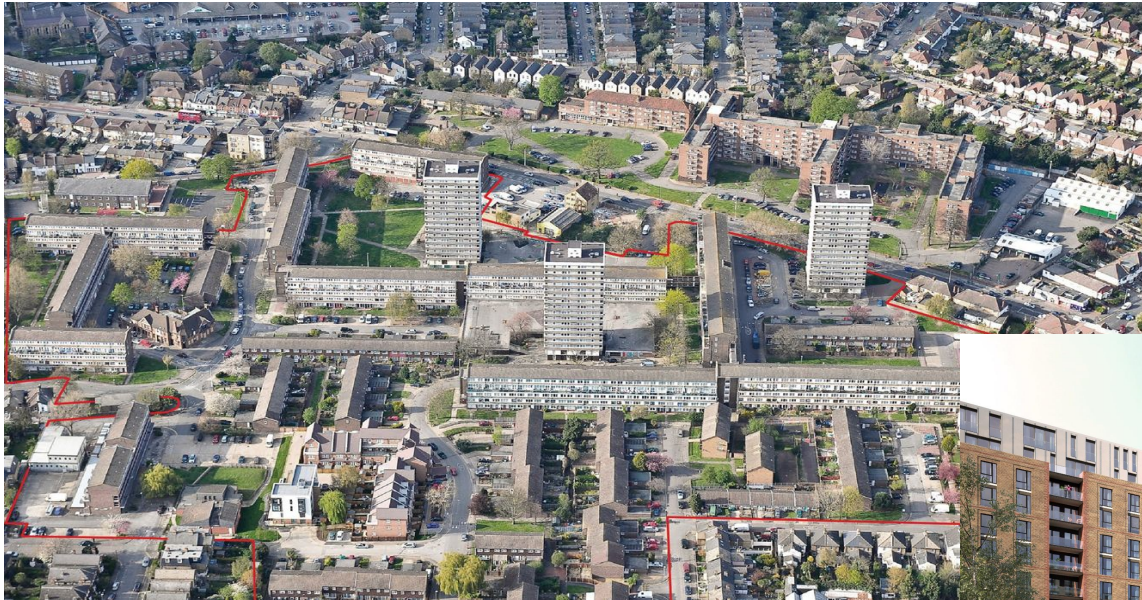

- *2,100 new modern homes*
- *New district heat system*
- *Community spaces, open spaces and workspace*





The Opportunity: New major development in Kingston town centre





The Opportunity: Existing large offtake sites (public sector)

Kingston University
London





The Opportunity: Current phase 1 design: off taker connections

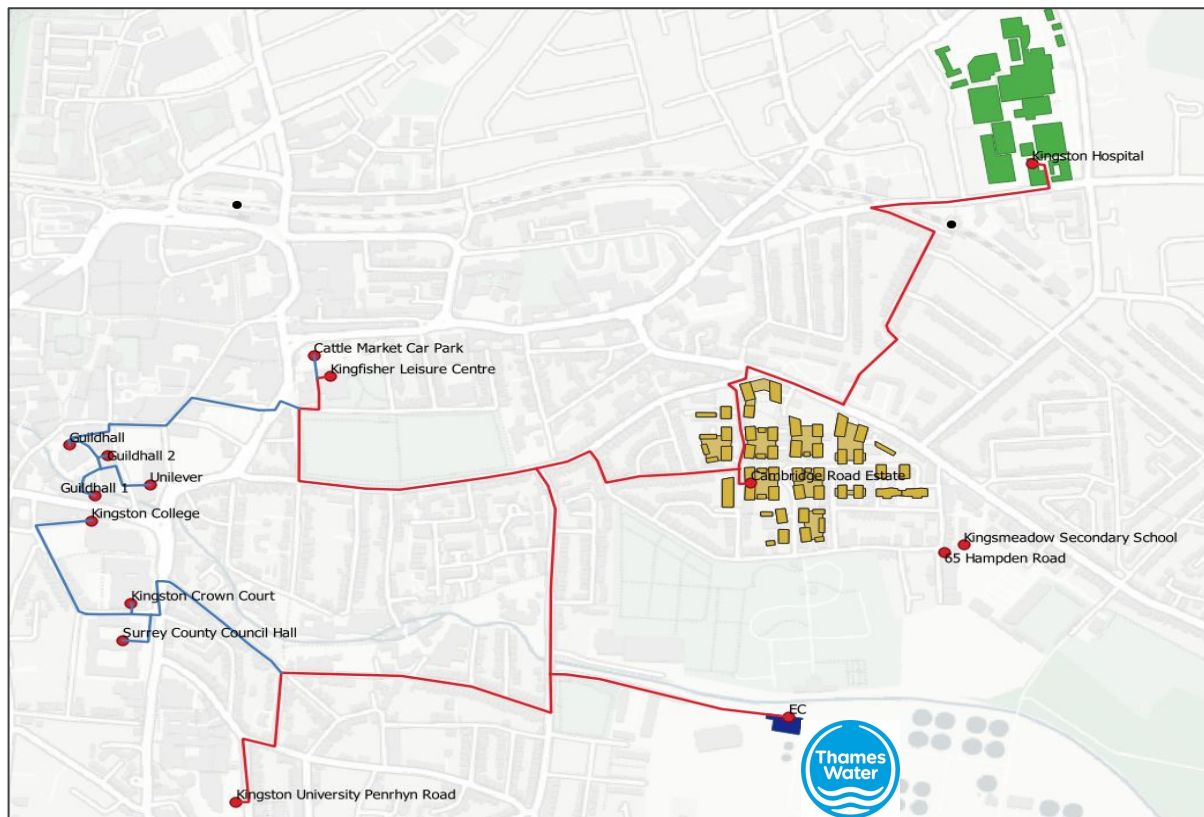



Carbon Savings and Modelling network

- Largest savings achieved from extending to the Town Centre
- **Kingston Hospital carbon savings represent 50% of the total 'Core network' emissions** – therefore a critical load for borough decarbonisation

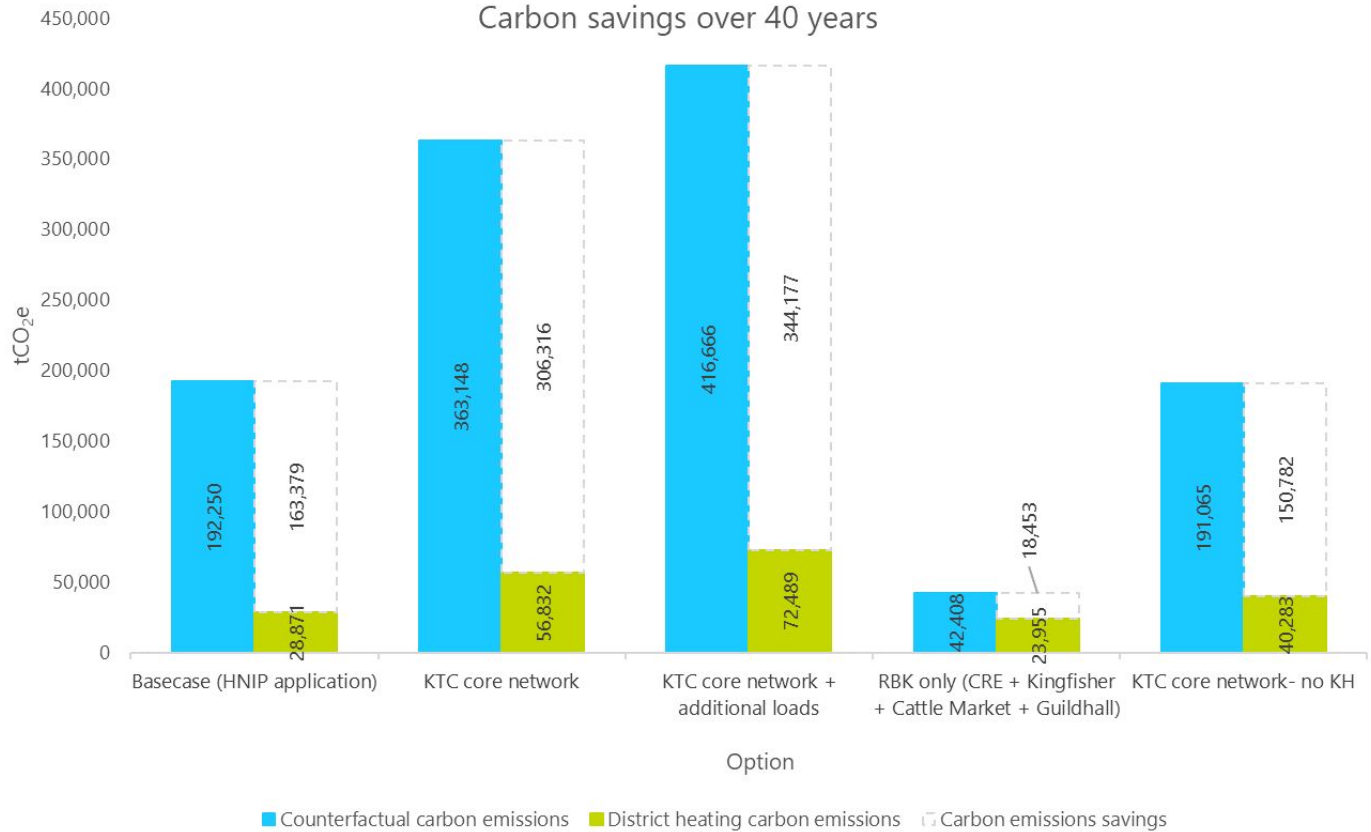



Scheme Design

3.2 Network schematic

The network schematic is shown in Figure 3-1. The following section details each heat supply and customer's connection requirements and configuration.

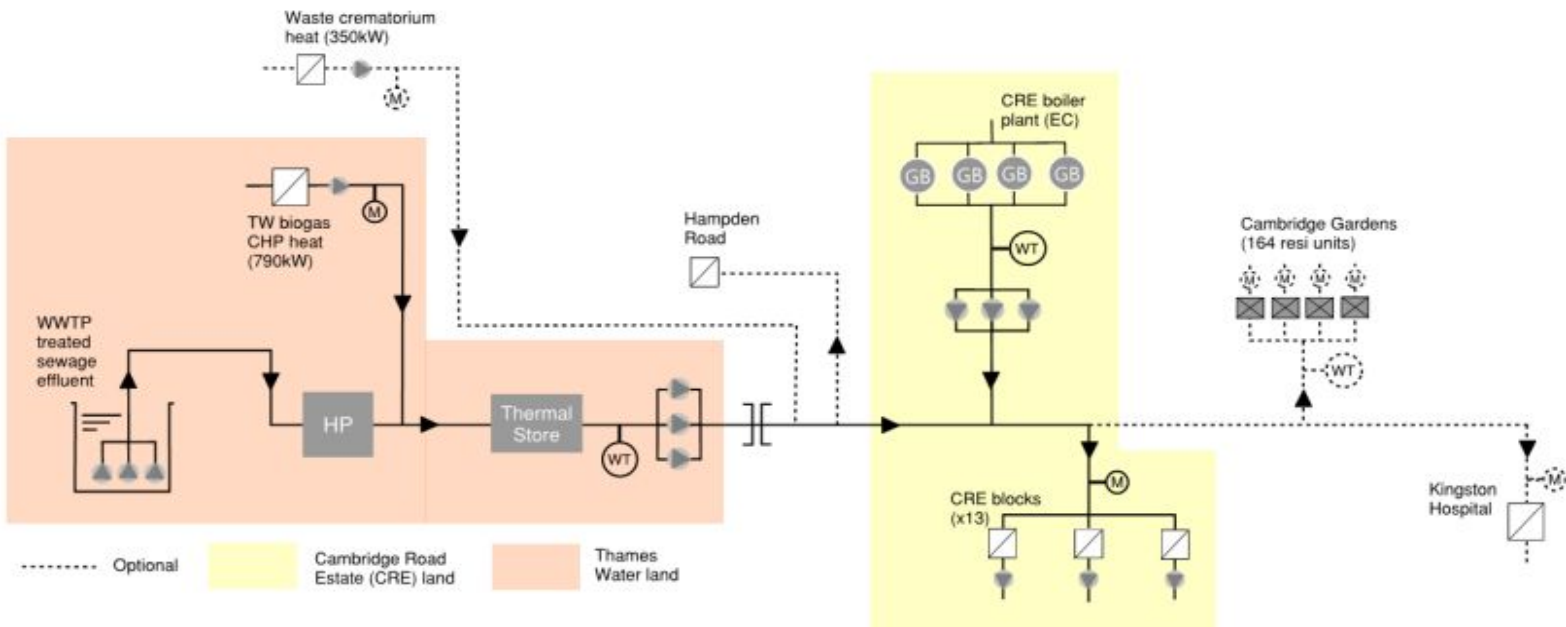



Scheme design

4.2.3 Preferred design

The design of the offtake (Option C - Figure 4-2) has been developed based on an iterative design process with feedback from Thames Water. The design minimises the risk to Thames Water operations while also providing a reliable flow of water to the heat pump.

The existing chamber is to be modified or replaced to divert flows to a new pumping chamber. A new sluice gate is suggested to facilitate maintenance and access to the pumps. This also ensures complete control of the discharge flow should Thames Water require it. The cold return can be placed inside the existing culvert, downstream of the new offtake chamber. This has the added benefit of the chamber's proximity to the proposed EC location (see Section 0). This means it may be possible to create a separate compound with private access from the RBK Recycling Centre.

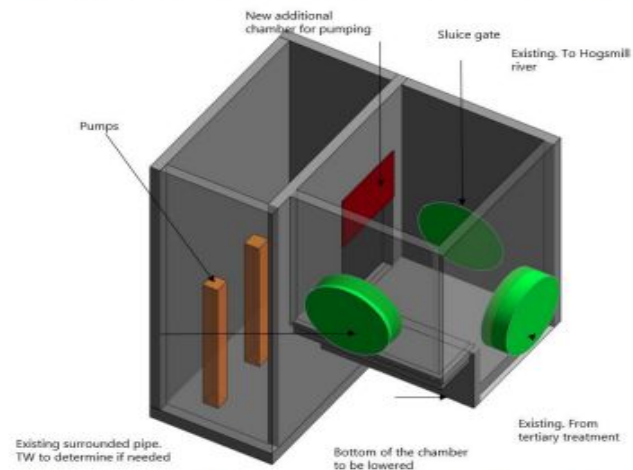

Figure 4-2 Option C Offtake drawing – BuroHappold initial proposal



Scheme Modelling

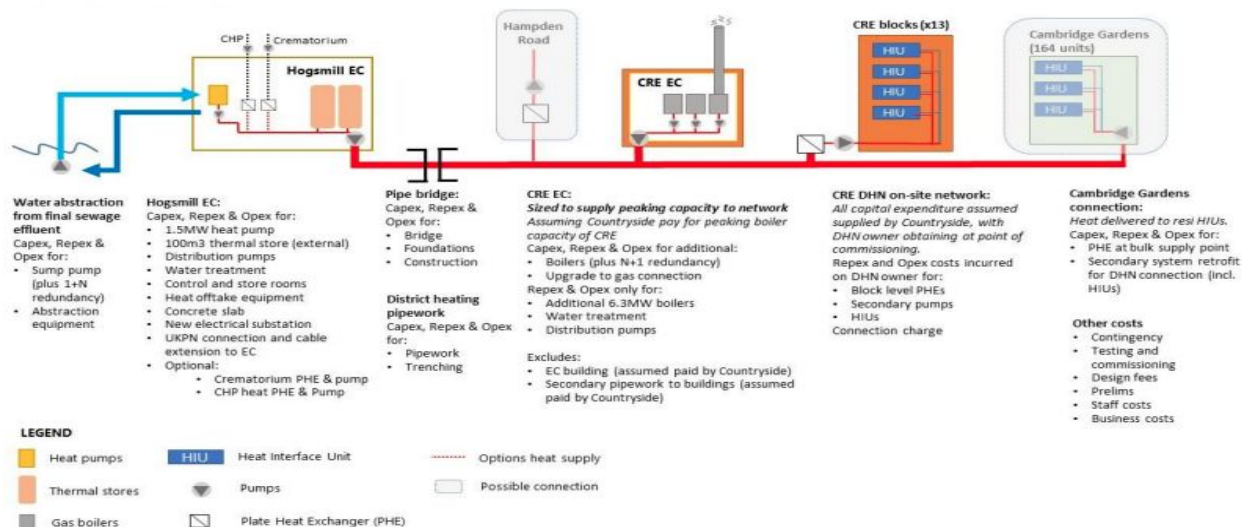

Figure 8-1 Modelling boundary and costing summary

Heat supply	Peak heat (kWth)	Max. annual heat supply (MWhth)
Heat pump	1,523	12,000
Biogas CHPs	790	6,000
Crematorium	350	730



The Journey to date (a decade in the making)....

Programme	Contractor	Relevant area of coverage
RBK Heat Mapping Study (2012)	URS	Kingston Town Centre, Tolworth
RBK Energy Master Plan (2013)	AECOM	Borough area
Kingston Decentralised Energy Network - Feasibility and business case study (Kt Town Centre Feasibility Study) (2015))	Arup	Redevelopment Kingston town centre, civic buildings, university
Phase 1 - Kingston Energy Masterplan (2017)	BuroHappold	Borough area
Phase 2 - Kingston Town Centre Pre-Feasibility Study (2019)	BuroHappold	Redevelopment Kingston town centre, civic buildings, university
Hogsmill Detailed Feasibility Study/Business Case (2020)	BuroHappold	Heat Supply from Thames Water Hogsmill WW plant to Cambridge Road Estate
Hogsmill Detailed Feasibility Study/Business Case - Extension (2021)	BuroHappold	Kingston Hospital site energy remodelling
Hogsmill Detailed Project Design - Techno Economic Model (TEM) (2021-22)	BuroHappold	Heat Supply from Thames Water Hogsmill WW plant to Cambridge Road Estate and Hospital and Town centre sites
Outline Business Case and GHNF bid Nov 2022	BuroHappold	Kingston Core Network

Thames Water hopes to harness human 'poo power' to heat homes

Company says sewage plan would avoid 105,000 tonnes of carbon dioxide emissions over 30 years





Some key lessons learned so far

1. Understand the key drivers of water companies and align early project objectives to the agenda of their business, by seeking common ground i.e Value for Money for their customers, cost efficiencies, new zero operations, regulatory compliance (OFWAT) and Best Value
2. Don't unrealistically raise expectation on commercial returns to the LA client and also private water companies in first 10-15 years of the project . Agree the delivery model
3. Ensure a consistent corporate and cross political commitment through 4 year administration cycles
4. Utilise the influence of strategic public and private sector partnerships to secure off takers and commitments ie. Hospital, University and big employers e.g. Unilever via planning agreements and Heads of Terms
5. Local Authorities can leverage these projects in many ways, do not underestimate use of planning powers, public borrowing, enforcement action, business rate, contacts with regional and UK government.
6. Ensure sufficient project partnership governance is in place, with escalation routes available
7. Build knowledge, skills, awareness and capacity of DHN within the organisation
8. Learn from other UK DHN projects especially and assure/engage regularly the Section 151 officer try to mitigate optimism bias with reality, yet work through with creative mitigation



Thank you for your time



Contact: Duncan Brown, Assistant Director of Regeneration & Economic Recovery , Kingston Council duncan.brown@kingsothn.gov.uk

